

THIS COPY IS PROVIDED ON A RESTRICTED BASIS AND IS NOT TO BE USED IN ANY WAY DETRIMENTAL TO THE INTERESTS OF PANDUIT CORP.

PANDUIT PART #	MILITARY PART # AND CLASS	STUD SIZE		DIMENSIONS in. [mm]					CA9 SERIES CRIMP DIE	CA-800(EZ) SERIES CRIMP DIE
		ENGLISH	METRIC	L± .03 [0,8]	W± .01 [0,3]	C± .02 [0,5]	M± .03 [0,8]	H± .01 [0,3]		
PNF18-4R-3K	-----	#4	--	.78 [19,8]	.25 [6,4]	.21 [5,3]	.65 [16,5]	.12 [3,1]	CD9-1A	CD-800-1
PNF18-4RN-3K	MS25036-148 CLASS 2	#4	--	.74 [18,8]	.22 [5,6]	.19 [4,8]	.63 [16,0]	.12 [3,1]		
PMNF1-3R-3K	-----	--	M3	.76 [19,3]	.23 [5,8]	.20 [5,1]	.66 [16,8]	.13 [3,3]		
PNF18-6R-3K	MS25036-102 CLASS 2	#6	M3,5	.70 [17,8]	.25 [6,4]	.21 [5,3]	.65 [16,5]	.15 [3,8]		
PNF18-6RN-3K	MS25036-101 CLASS 2	#6	M3,5	.74 [18,8]	.22 [5,6]	.16 [4,0]	.63 [16,0]	.15 [3,8]		
PNF18-8R-3K	MS25036-149 CLASS 2	#8	M4	.86 [21,8]	.31 [7,9]	.25 [6,4]	.70 [17,8]	.17 [4,3]		
PNF18-10R-3K	MS25036-103 CLASS 2	#10	--	.86 [21,8]	.31 [7,9]	.25 [6,4]	.70 [17,8]	.20 [5,1]		
PMNF1-5R-3K	-----	--	M5	.88 [22,4]	.35 [8,9]	.25 [6,4]	.71 [18,0]	.21 [5,3]		
PNF18-14R-3K	MS25036-150 CLASS 2	1/4"	M6	1.06 [27,0]	.46 [11,7]	.38 [9,7]	.84 [21,3]	.27 [6,9]		

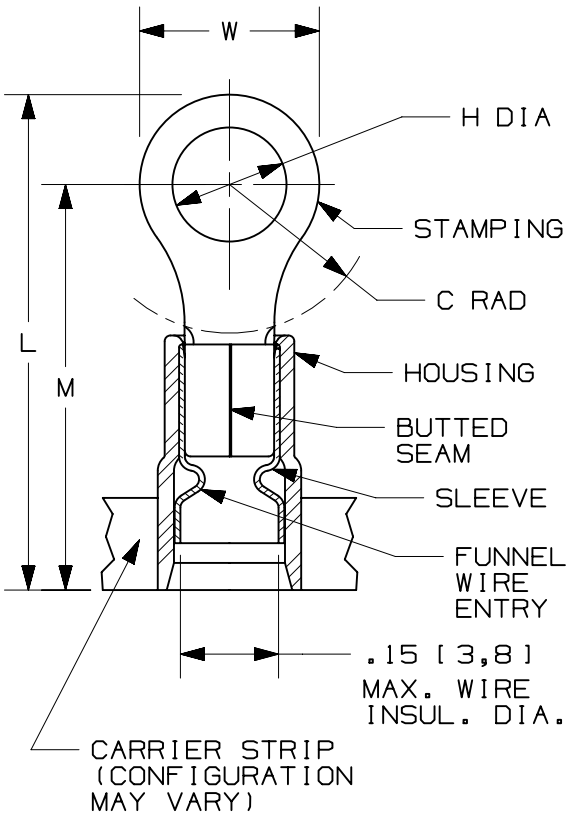

PRESS/APPLICATOR COMPATIBILITY CHART

PRESS	CP-871	CP-861
APPLICATOR	CA9 CA-800EZ	CA-800

- NOTES:
- cULus LISTED FOR:
 - A. #22-18 AWG [0,5-1,0 mm²] SOLID OR STRANDED COPPER WIRE
 - B. 221°F [105°C] MAX. OPERATING TEMPERATURE
 - C. 600 V. MAX. VOLTAGE RATING
 - SEE www.panduit.com FOR PACKAGE QUANTITIES
 - MATERIAL:
 - A. STAMPING: .03" [0,8] THK COPPER, TIN PLATED
 - B. HOUSING: NYLON, RED
 - C. SLEEVE: BRASS, TIN PLATED
 - DIMENSIONS IN BRACKETS ARE METRIC EQUIVALENT
 - WIRE STRIP LENGTH: 1/4" ^{+1/32}/₀ [6,4^{+0,8}/₀]

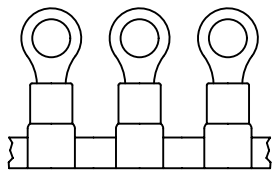

TITLE RING TERMINALS, 3 PC. NYLON FUNNEL INSULATED, #22-18, CONTINUOUS REEL CUSTOMER DRAWING			
ITEM REVISION NAME N41145BA/09		PANDUIT	
DATASET FILE NAME N41145BA_DC/09A			
UNLESS OTHERWISE SPECIFIED, DIMENSIONAL TOLERANCES ARE: IN [mm]		MATERIAL: SEE NOTES	
.X ± .XX ±		.XXX ± ANGLES ±	
DRAWN BY FES		DATE -	
CHK FS		SCALE N.T.S.	
DRAWING NUMBER: A41145		SHT 1 OF 1	
REV		DATE	
BY		CHK	
APR		DESCRIPTION	
ECN		SIZE A	

D10100DA/15