

Typ-Nr. E13419  
E13420

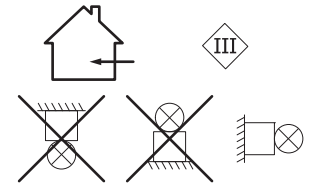
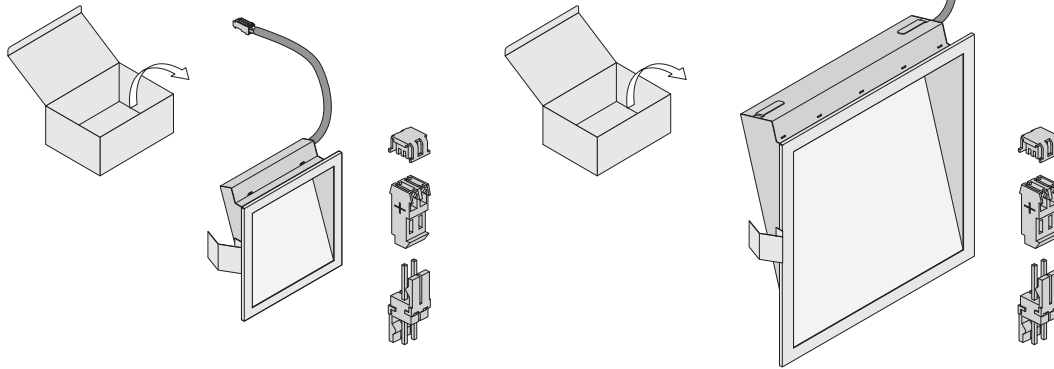

UK CA  
Thorn Lighting Limited  
Durhamgate Spennymoor  
Co. Durham DL16 6HL UK  
Zumtobel Lighting GmbH  
Schweizerstrasse 30  
6850 Dornbirn AUSTRIA

**ZUMTOBEL**  
EAC CE III  
Mod ----  
Ser ----  
Typ ---- LED... W 24V DC

Info on (non-) replaceability

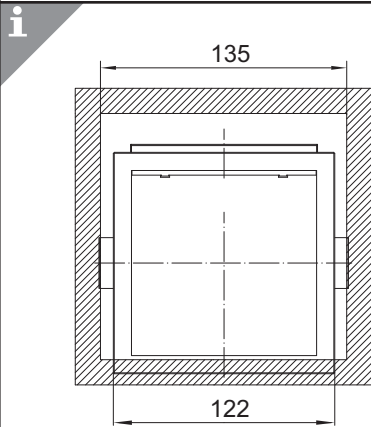
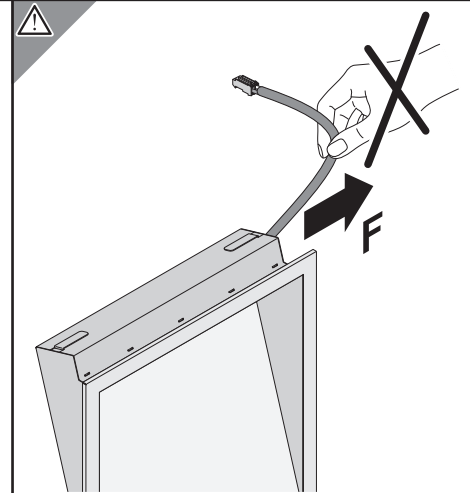

**E13419**

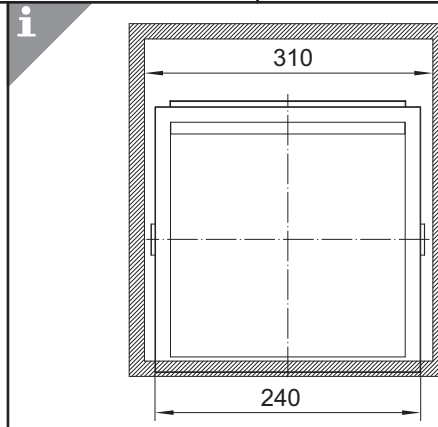
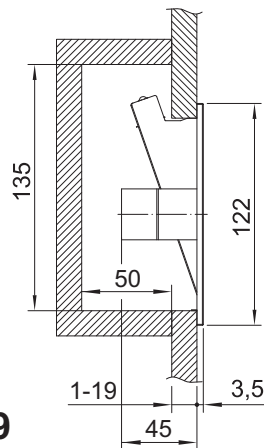

**E13420**

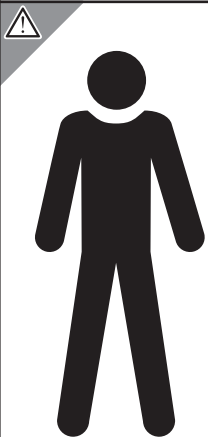
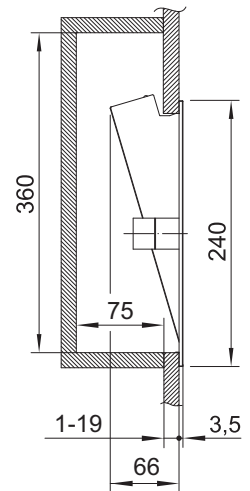

**DE** Die Montage und Inbetriebnahme darf nur von autorisiertem Fachpersonal durchgeführt werden.

**NL** De montage en inbedrijfstelling mogen enkel door erkend vakpersoneel worden uitgevoerd.

**EN** Installation and commissioning may only be carried out by authorized specialists.

**NO/SE** Monteringen och idrifttagandet får endast företas av aENToriserad fackpersonal.

**FR** L'installation et la mise en service doivent obligatoirement être effectuées par des techniciens.

**FI** Asennuksen ja käyttöönoton saa tehdä vain aENTorisoitu ammattihenkilöstö.

**IT** Montaggio ed avviamento devono essere eseguiti solo da personale specializzato.

**ES** El montaje y la puesta en marcha sólo puede ser realizado por personal especializado autorizado.

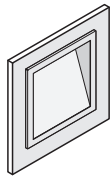

**DE** Die Leuchte dient ausschließlich der Beleuchtung und ist entsprechend den nationalen Errichtungsbestimmungen zu installieren. Eine andere Nutzung oder ein anderer Einbau gilt als „nicht bestimmungsgemäß“.

**EN** The luminaire is used exclusively for lighting and is to be installed in accordance with the national installation regulations. Any other use or installation is regarded as "not according to instructions".

**FR** Le luminaire sert uniquement à l'éclairage et doit être installé conformément aux prescriptions nationales en matière d'installation. Toute autre utilisation ou installation est considérée comme "non conforme".

**IT** L'apparecchio è destinato esclusivamente all'illuminazione e va installato in conformità alle leggi nazionali in vigore. Un altro impiego o un diverso tipo di montaggio non è considerato conforme alle disposizioni.

**NL** De lamp dient uitsluitend voor de verlichting en dient conform de nationale bouwbepalingen te worden geïnstalleerd. Een ander gebruik of een andere inbouw is niet conform.

**NO/SE** Armaturen är uteslutande avsedd för belysning och ska installeras i enlighet med de nationella installationsbestämmelserna. All annan användning eller montering gäller som "icke ändamålsenlig".

**FI** Valaisin on tarkoitettu ainoastaan valaistuskäyttöön, ja se on asennettava kansallisten määräysten mukaan. Muu käyttö tai muu asennus katsotaan sopimuksenvastaiseksi käytöksi.

**ES** La lámpara está destinada exclusivamente a la iluminación y debe ser instalada de acuerdo con las pertinentes normas nacionales. Cualquier otro uso o instalación no se considerará "previsto por la norma".

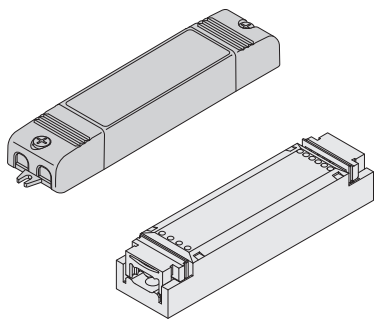

**DE** Betriebsgeräte müssen für LED-Module geeignet sein und der Norm EN 61347-2-13 entsprechen.

**EN** Control gear must be suitable for LED modules and comply with the EN 61347-2-13 standard.

**FR** Les appareillages doivent convenir pour les modules LED et être en conformité avec la norme EN 61347-2-13.

**IT** Gli alimentatori devono essere adatti ai moduli LED e conformi alla normativa EN 61347-2-13.

**NL** Bedrijfsapparaten moeten geschikt zijn voor LED-modules en voldoen aan de norm EN 61347-2-13.

**NO/SE** Styringsenheter må være egnet til LED-moduler og være i samsvar med standard EN 61347-2-13.

**FI** Käyttölaitteiden on oltava led-moduuleille sopivia ja täytettävä standardin EN 61347-2-13 vaatimukset.

**ES** Los aparatos de servicio deben ser apropiados para los módulos LED y cumplir la norma EN 61347-2-13.

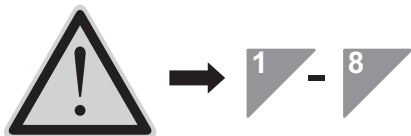

**DE** **Achtung!** Während der Verdrahtung und Installation der Leuchten und Versorgungsgeräte immer spannungslos arbeiten. Nichtbeachtung kann zur Zerstörung der LED-Module führen.

**EN** **Caution!** Make sure that the luminaires and power supply units are always disconnected from the mains supply during wiring and installation work. Otherwise, the LED modules may be destroyed.

**FR** **Attention!** Toujours travailler sans tension lors du câblage et de l'installation des luminaires et unités d'alimentation. Le non-respect de cette consigne peut entraîner la destruction des modules à LED.

**IT** **Attenzione!** Lavorare sempre in assenza di tensione mentre si cablano e si installano gli apparecchi e le unità di alimentazione. In caso contrario i moduli LED possono andare distrutti!

**NL** **Opgelet!** Tijdens het bedraden en installeren van de armaturen en voedingsapparaten altijd zonder spanning werken. Bij niet-naleving hiervan kunnen de LED-modules ernstig worden beschadigd.

**NO/SE** **OBS!** Koble alltid fra strømmen ved kabling og installasjon av lampene og strømforsyningsenheterne. LED-modulene kan ødelegges dersom dette ignoreres.

**FI** **Huom!** Valaisimien ja syöttölaitteiden kytkemisen ja asentamisen aikana on aina työkenneltävä jännitteettömästi. Muutoin led-moduulit voivat tuhoutua.

**ES** **Atención** Siempre mantenga desconectada la tensión al realizar las tareas de cableado y de instalación de las luminarias y dispositivos de alimentación. De lo contrario podría destruirse el módulo LED.

1

2 x 0,75-1,0 □

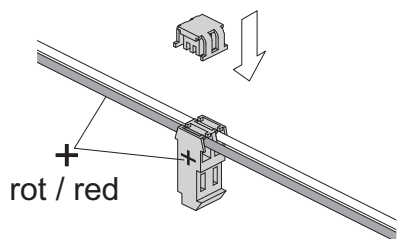

2

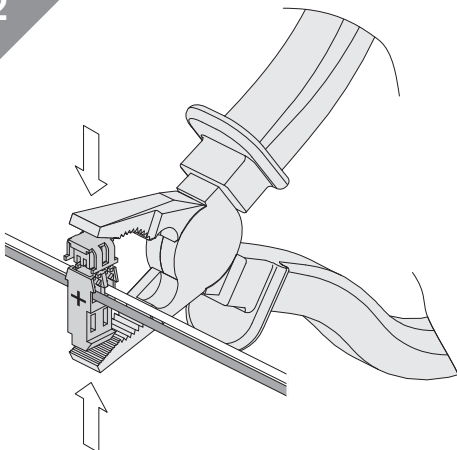

3

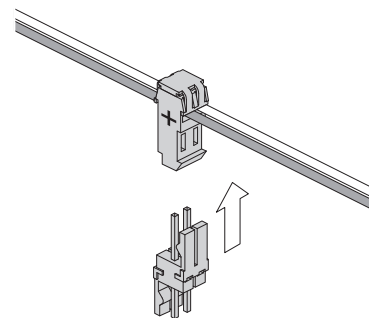

**4**

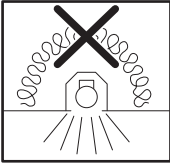

**DE** Leuchte darf nicht mit Wärmedämmung abgedeckt werden.

**EN** Luminaire not suitable for covering with thermally insulating material.

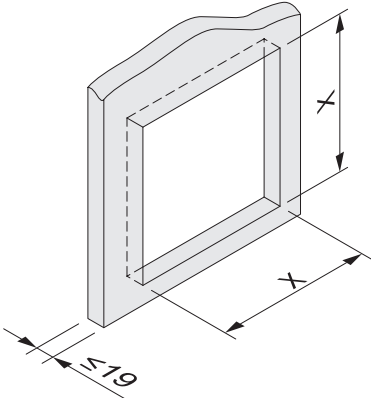

	E13419	E13420
X	110	220

**5**

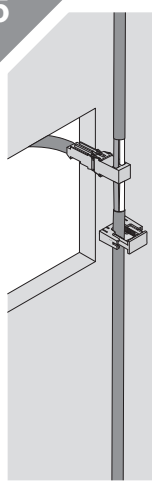

**DE** Schlitz- und Einbaumontage: Zugentlastung bauseits erforderlich. Anschlussleitung ortsfest verlegen.

**EN** Slot and recessed mounting: Strain relief required on site. Fix the connecting cable in position.

**FR** Montage dans la découpe ou encastrément: Serre-câble nécessaire in situ. Le câble d'alimentation doit être fixé en position.

**IT** Montaggio in fessura e incassi: È necessario predisporre pressacavi sul posto. Fissare il cavo al piano d'appoggio.

**NL** Sleuf- en inbouwmontage: Snoerontlasting moet ter plaatse worden voorzien. Aansluitleiding ter plaatse vast installeren.

**NO/SE** Infälld och slitsmontering: Dragavlastning krävs vid installation. Tilkoblingsledningarna legges stasjonært.

**FI** Rako- ja uppoasennus: Vetokevennyksen oltava rakennuksen puolella. Aseta liitosjohto kiinteästi.

**ES** Montaje en carril o empotrado: -A pie de obra deberán colocarse dispositivos antitracción. Tender fijamente el cable de conexión.

**6**

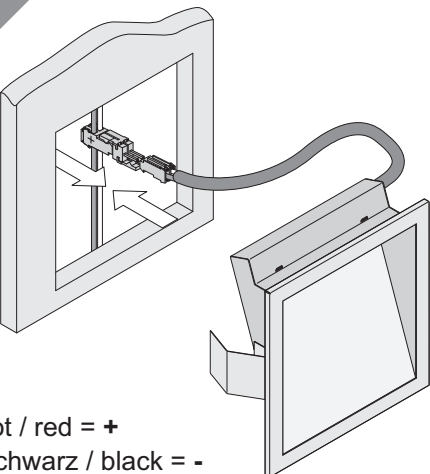

rot / red = +  
schwarz / black = -

**7**

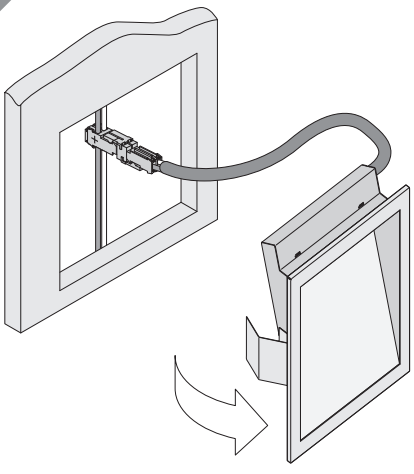

**8**

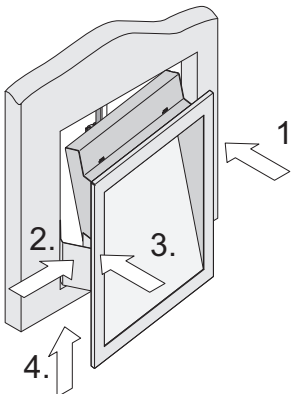

Zubehör - Accessory - Accessoire éventuel - Accessori  
Toebehoren - Tillbehör - Lisätarvike - Accesorios

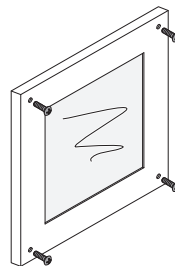
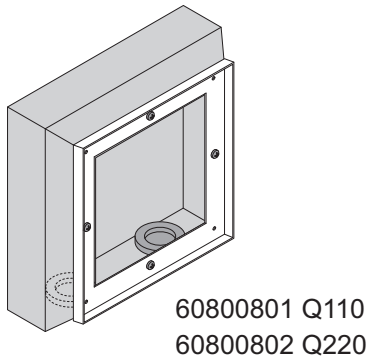

60800805 Q220 COVER CL  
60800806 Q220 COVER MT

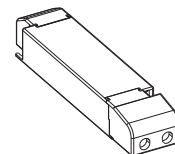
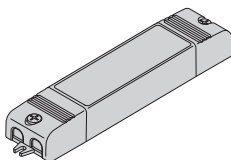

Technische Änderungen vorbehalten. - Specifications subject to change without notice. - Modifications techniques sans préavis.  
Modifiche tecniche senza preavviso. - Technische wijzigingen voorbehouden.  
Med forbehold om tekniske endringer. - Oikeudet teknisiin muutoksiin pidätetään. - Modificaciones técnicas sin preaviso.