

## panel mounting appliance inlet - with closure cap



Product description	
BALS-Prd.-Nr	26057
EAN	4024941260572
Product category	TE surface mounting appliance inlet Quick-Connect
Current	32A
Number of poles	5p
Arrangement of phases	3p+N+PE
Position of earth contact	6 h
Voltage	200/346 - 240/415V~
Frequency	50/60Hz

Product description	
Protection degree	IP67
Colour code	red RAL 3000
Colour of appliance	Closure cap grey RAL 7035, Bayonet ring grey RAL 7035, Enclosure grey RAL 7035, Collar red RAL 3000
Connection design	screwless spring-clamp technology
Maximum conductor size	6,0 qmm
Cable entry	other
Height	148mm
Width	100mm
Depth	123mm
Flange size vertical in mm	75mm
Flange size horizontal in mm	90mm
Drill hole dist. vertical mm	45mm
Drill hole dist. horizontal mm	78mm
Material of enclosure	Polyamide
Contacts	The contact carrier is made of high temperature resistant material, the contacts are brass nickel plated

Additional technical properties	
	With closure cap

Logistics data	
Weight/pcs	0.402 kg / Piece
Packaging	Bag
Content amount	1 ST
EAN	4024941260572
Length	123 mm
Width	100 mm
Height	148 mm
Weight	0.403 kg
Volume	1,820.4 ccm
Packaging	Carton
Content amount	10 ST
EAN	4024941962100
Length	330 mm
Width	216 mm
Height	260 mm
Weight	4.246 kg
Volume	17,062.5 ccm

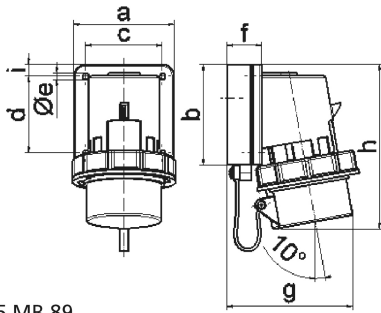

5 MB 89

Ampere	16	32				
Polzahl	5	5				
a	84,0	90,0				
b	84,0	75,0				
c	64,0	78,0				
d	64,0	45,0				
e ø	5,5	5,5				
f	28,0	28,0				
g	111,0	123,0				
h	137,0	148,0				
i	10,0	13,0				
Leiter mm <sup>2</sup> min	1	2,5				
Leiter mm <sup>2</sup> max	2,5	6				