

Warewashing
Undercounter WSC, single skin, drain
pump, detergent & rinse aid dispensers,
720d/h, 60Hz

ITEM # _____

MODEL # _____

NAME # _____

SIS # _____

AIA # _____

400260 (ELA3GTL6)

Undercounter Dishwasher with WASH-SAFE CONTROL, single skin, built-in drain pump, detergent and rinse aid dispensers, 3 phase, 720d/h, 60Hz - Thermal label compliant

Short Form Specification

Item No. _____

Unit shall be Electrolux Professional undercounter type hot water rinsing dishmachine which is designed in compliance with thermal label test. Electrical characteristics to be 230 volts three phase 60Hz operation, convertible to single phase on-site. Washing performance is ensure by a powerful wash pump, large capacity wash tank, upper and lower revolving spray arms. Soft start wash pump to avoid accidental breakage of crystal wares. Constant rinse temperature and pressure guaranteed by built-in atmospheric boiler and rinse booster pump. Unit to feature "Wash-Safe Control" led light. Green light will indicate that all washed items have been properly rinsed. Uses 3 liters of clean water per final rinse. Three automatic cycles for different types of wares. Double skin insulated door. 304 AISI stainless steel construction to include door, external panels, frame, wash tank and tank filters. The unit shall include drain pump, detergent and rinse aid dispenser pumps and is equipped with electric cable.

Main Features

- Incorporated Soft Start feature to offer additional protection to more delicate items.
- Washing system endowed with rotating washing arms, high powered wash pump and large capacity boiler for professional washing.
- 4 second (variable) pause after washing and before rinsing ensures that no drops of unclean water will fall on the clean items at the end of the rinsing cycle.
- Fully automatic self-cleaning cycle avoids the risk of bacteria proliferation.
- Simple control panel with digital display allows on-site personalization of washing and rinsing cycle times and temperatures as well as precise rinse aid and detergent quantities to suit customer's needs.
- Simple service from the front.
- IPx4 water protection.
- Pre-arrangement for HACCP system implementation and Energy Management device.
- An effective rinse system uses only 3 liters of clean hot water per basket for lower running costs.
- Digital read-out keeps operator informed as to temperatures.
- State-of-the-art electronic controls with built-in programming, self-diagnostics for serviceability and automatic interior self-cleaning cycle.
- Unique temperature interlock guarantees required temperatures in both the wash and final rinse in case of emergency cold water feeding.
- Constant temperature of 84 °C throughout the rinsing cycle regardless of the network's water pressure and temperature.
- Built-in rinse aid and detergent dispenser with automatic initial and continuous cycle loading for perfect result while minimizing service and maintenance needs.
- Green light of "WASH SAFE CONTROL" confirms that items have been rinsed properly.
- High efficiency air gap (class A) in water inlet circuit to avoid water being siphoned back into the network as a result of a sudden drop in main pressures.
- Three phase or single phase electrical connection, convertible on-site.
- Washing capacity of 40 baskets or 720 dishes per hour.
- Built-in atmospheric boiler sized to raise incoming water to 84 °C minimum for sanitizing rinse. No external booster is required.
- The unit is designed in compliance with Marriott's Food Safety Operational Standards, NSF ANSI standard, thermal label test, DIN 10512.
- 90/180/120 seconds cycle. The short cycle is for light soiled items as glasses, the medium cycle is for mixed soiled items while the long cycle is for normal soiled items as dishes.
- An effective rinse system uses 3 liters (short cycle) or 3.5 liters (medium cycle) or 4 liters (long cycle) of clean hot water per basket for low running costs and Marriott's Food Safety Operation Standards,

APPROVAL: _____

NSF ANSI standard, thermal label test, DIN 10512 compliant.

- Cover rack for small and light items (500x500 baskets) PNC 867016

Construction

- Unit to feature smooth surfaces to facilitate cleaning.
- 304 stainless steel boiler with higher welding protection to increase resistance to corrosion.
- PVC water supply hose with metal connections resistant to high water pressure.
- Completely closed on the back by a cover plate.
- Element protection from dry fire and low water.
- Interchangeable wash/rinse arms screw out for simple clean up.
- The boiler drain facilitates the evacuation of stagnant water after long periods of inactivity to ensure a higher level of hygiene.
- Double skin insulated door to reduce heat dispersion.
- Large wash tank with round corners and no pipes to avoid dirt built-up.
- Incorporated drain pump to control water level in wash tank draining.
- Large tank filter collects the soil to keep the wash water clean for a longer time and have better washing performance.
- Unit to feature drain pump, rinse aid and detergent dispenser pumps.
- Front panel door, wash tank and tank filters made in heavy duty anti-corrosive AISI 304 stainless steel.

Included Accessories

- 1 of Stainless steel tank filter for single skin undercounter PNC 864222
- 1 of Yellow cutlery container PNC 864242
- 1 of Basket for 18 dinner plates - yellow PNC 867002

Optional Accessories

- 12lt external manual water softener PNC 860412
- 8lt external automatic water softener PNC 860413
- Stand for undercounter dishwasher PNC 860418
- External detergent level probe kit PNC 864004
- External rinse aid level probe kit PNC 864005
- Kit 4 flanged feet for undercounter dishwashers PNC 864009
- Stainless steel inlet hose kit PNC 864016
- Filter for partial demineralization PNC 864017
- Kit to measure total and partial water hardness PNC 864050
- Yellow cutlery container PNC 864242
- Filter for total demineralization PNC 864367
- Reverse osmosis filter for single tank Dishwasher with atmosphere boiler PNC 864388
- Pressure reducer for single tank dishwasher PNC 864461
- Half size basket universal PNC 864527
- Half size basket for plates PNC 864528
- Half size basket for glasses PNC 864529
- Kit 4 plastic boxes for cutlery - yellow PNC 865574
- Basket for 18 dinner plates - yellow PNC 867002
- Basket for 48 small cups or 24 cups - blue PNC 867007

Front

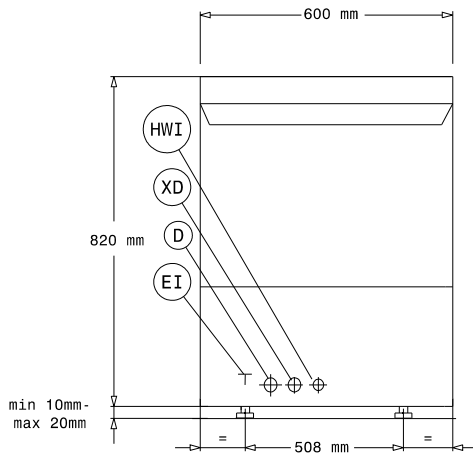

Side

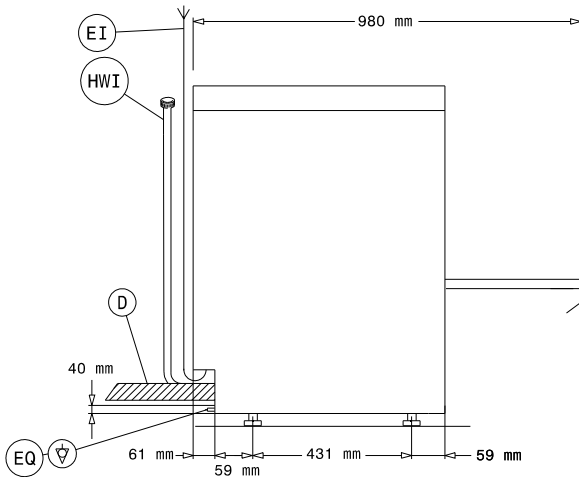

- D = Drain
- EI = Electrical inlet (power)
- EO = Electrical Outlet
- HWI = Hot water inlet
- XD = Detergent connection
- XR = Rinse aid connection

Top

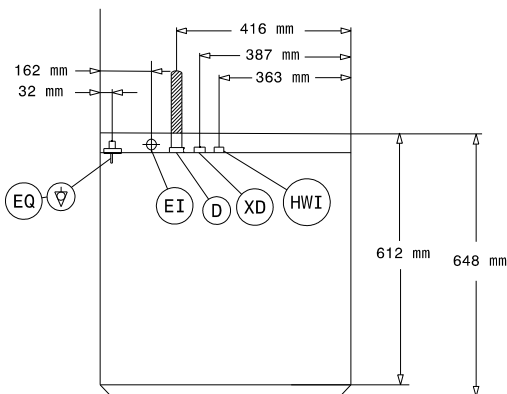
Electric

Supply voltage:	400260 (ELA3GTL6)	230 V/3 ph/60 Hz
Convertible to:		230V 1N~; 400V 3N~
Default Installed Power:		5.35 kW
Boiler heating elements:		4,5 kW
Tank heating elements:		2 kW
Wash pump size:		0.736 kW

Water:

Pressure, bar min/max:	0.5-7 bar
Water supply temperature*:	10-60 °C
Drain line size:	40 mm
Inlet Water supply pressure:	7 - 102 psi (0.5 - 7 bar)
Washing tank capacity (lt):	33
Water consumption per cycle (lt):	
Boiler Capacity (lt):	5,8

Key Information:

Baskets per hour*:	40
Dishes per hour:	720
Working cycles time (sec.):	90/120/240
Wash temperature:	75-78°C
Cell dimensions - width:	500 mm
Cell dimensions - depth:	500 mm
Cell dimensions - height:	330 mm
Rinse temperature:	87-90 °C
External dimensions, Width:	600 mm
External dimensions, Depth:	648 mm
External dimensions, Height:	820 mm
Packaging size (WxDxH):	600x610x820 mm
Noise level:	<70 dBA